

AIR FORCE T.O. 35C2-3-442-14
 ARMY TM5-6115-600-24P
 NAVY NAVFAC P-8-628-24P
 MARINE CORPS SL-4-07464B

SECTION II. REPAIR PARTS FOR ORGANIZATIONAL, INTERMEDIATE (FIELD),
 (DIRECT AND GENERAL SUPPORT) AND DEPOT MAINTENANCE

(1) ILLUS- TRATION		(2) SMR CODE				(3) USMC		(4)	(5) DESCRIPTION	(6)	(7) QTY INC IN UNIT	(8) USMC QTY PER EQUIP	
a	b	a	b	c	d	a	b	NATIONAL STOCK NUMBER	REF NUMBER & MFR CODE	USABLE ON CODE	U/M		
FIG NO.	ITEM NO.	ARMY	AIR FORCE	NAVY	USMC	SSI	REPL FACTOR						
									GROUP 10 - ENGINE				
									AIR CLEANER AND RELATED PARTS				
53	1	PAOZZ	PAOZZ	PAFZZ	PAFZZ	D	.008	5305-00-225-8507	SCREW, HEX HEAD MS90725-43	96906	EA	2	2
53	2	PAOZZ	PAOZZ	PAFZZ	PAFZZ	D	.008	5310-00-245-3424	NUT, SELF-LOCKING MS17829-5C	96906	EA	2	167
53	3	PAOZZ	PAOZZ	PAOZZ	PAOZZ	D	.008	5305-00-942-2196	SCREW, HEX HEAD MS90725-80	96906	EA	2	8
53	4	PAOZZ	PAOZZ	PAOZZ	PAOZZ	D	.008	5310-00-483-8790	NUT, SELF-LOCKING MS17829-6C	96906	EA	2	25
53	5	PAOZZ	PAOZZ	PAOZZ	PAOZZ	D	.010	5310-00-080-6004	WASHER, FLAT MS27183-14	96906	EA	4	43
53	6	XB	XB	XB	XB				BRACKET 71-4623	30554	EA	1	1
53	7	PAOZZ	PAFZZ	PAFZZ	PAFZZ		.030	5330-00-440-9323	PACKING, PREFORMED 7L7460	11083	EA	1	1
53	8	XB	XB	XB	XB				COUPLING SL5344	11083	EA	1	1
53	9	PAOZZ	PAFZZ	PAFZZ	PAFZZ		.030	5330-00-440-9325	PACKING, PREFORMED 7L2031	11083	EA	1	1
53	10	AOO	AOO	AOO	AOO				AIR CLEANER ASSY 71-4399	30554	EA	1	1
53	11	PAOZZ	PAOZZ	PAOZZ	PAOZZ	D	.008	6310-00-063-6716	NUT, PLAIN WING MS35426-14	96906	EA	2	2
53	12	PAOZZ	PAOZZ	PAOZZ	PAOZZ	D	.010	5310-00-582-9965	WASHER, LOCK MS33338-44	96906	EA	2	154
53	13	PAOZZ	PAOZZ	PAOZZ	PAOZZ	D	.010	5310-00-809-4058	WASHER, FLAT MS27183-10	96906	EA	2	252
53	14	XB	XB	XB	XB				RETAINER, AIR CLEANER 70-4398	30554	EA	1	1
53	15	PAOZZ	PAOZZ	PAOZZ	PAOZZ		.870	2940-00-463-1362	FILTER, ELEMENT 70-1251	30554	EA	2	2
53	16	PAOZZ	PAOZZ	PAOZZ	PAOZZ	D	.008	5310-00-959-7600	NUT, SELF-LOCKING MS51922-5	96906	EA	4	4
53	17	PAOZZ	PAOZZ	PAOZZ	PAOZZ	D	.008	5307-00-216-8603	STUD, PLAIN 70-4358	30554	EA	2	2
53	18	PAOZZ	PAOZZ	PAOZZ	PAOZZ	D	.060	5930-00-430-3532	SWITCH PRESSURE, FILTER 70-1310 899-0001	30554 07988	EA	1	1
53	19	PAOZZ	PAOZZ	PAOZZ	PAOZZ	D	.008	4730-00-188-3513	PLUG, PIPE MS20913-2	96906	EA	2	3
53	20	PAOZZ	PAOZZ	PAOZZ	PAOZZ	D	.006	4730-00-177-6166	TBE, STREET 71-4863 1/4 MRO-5	30554 08752	EA	1	1
53	21	XA	XA	XA	XA				FRAME, AIR CLEANER 71-4397	30554	EA	1	1

AIR FORCE
ARMY
NAVY
MARINE CORPS

Current part is item (18) on diagram. Available at www.oshkoshequipment.com

F.O. 35C2-3-442-14
TM5-6115-600-24P
NAV FAC P-8-628-24P
SL-4-07464B

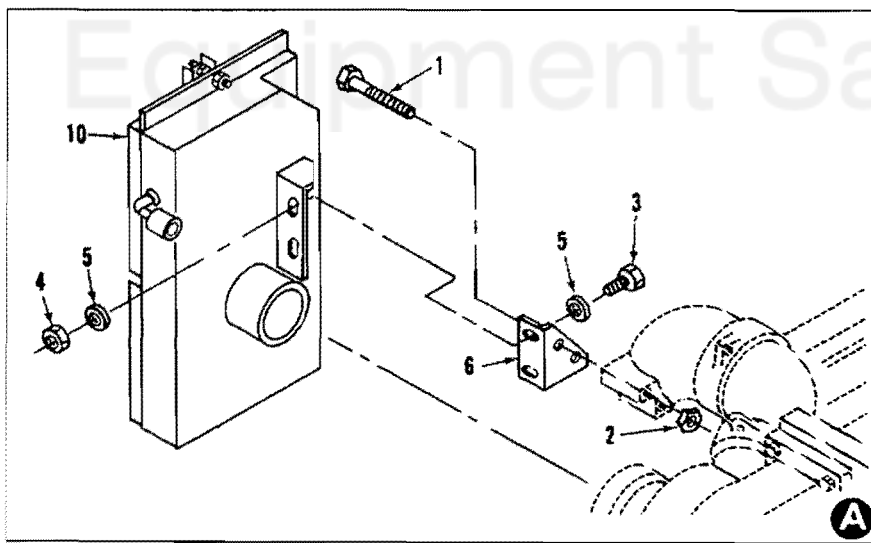
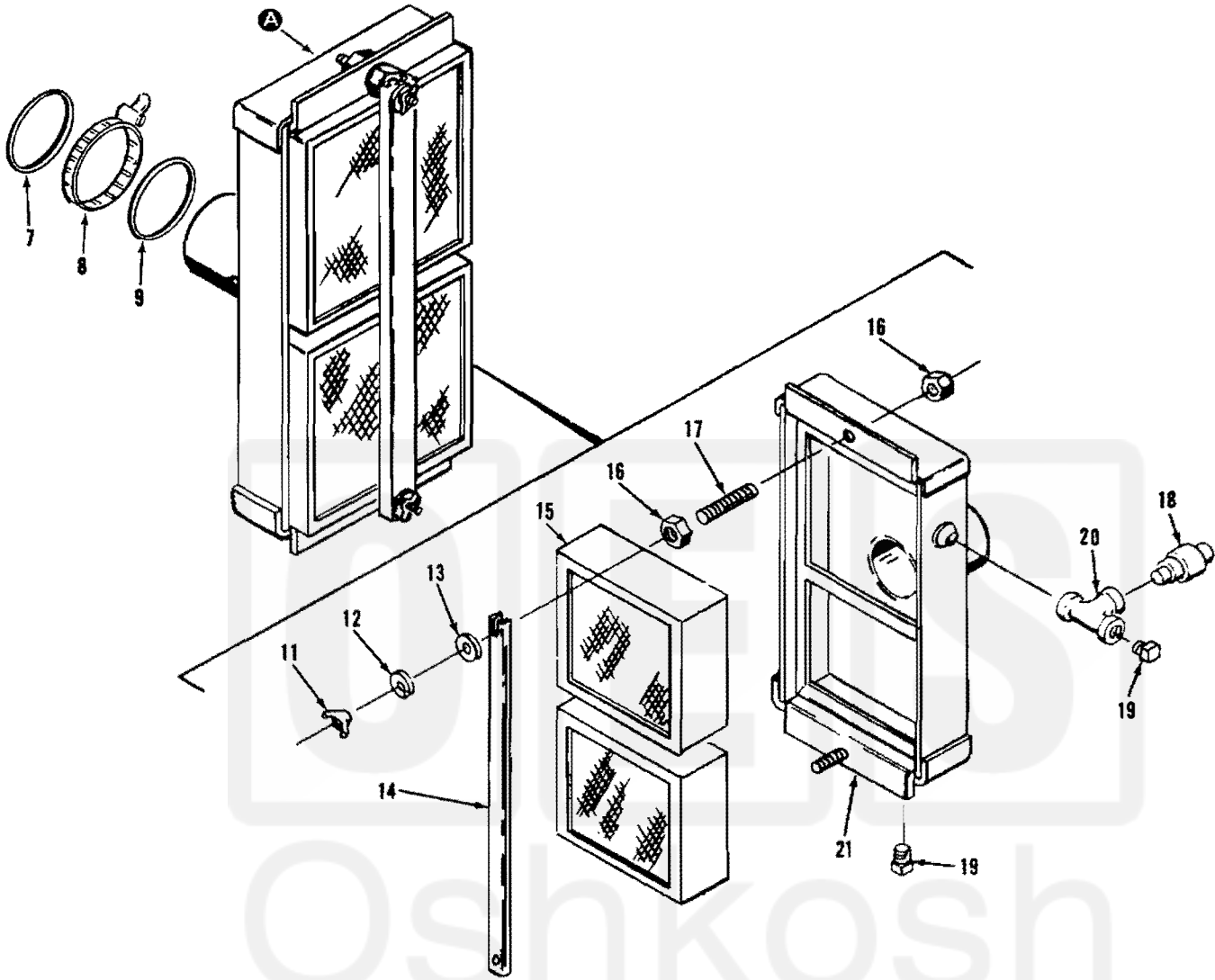

Figure 53. Air Cleaner and Related Parts

Current part is item (18) on diagram. Available at www.oshkoshequipment.com